



Series 1221

Flanged Chamber

External Mount, Pressure to 1000 psig (69 bar), Hermetically Sealed Switches, Temperature to 475°F (246°C), Minimum Specific Gravity 0.40



Series 1223 has one vertical and one horizontal flanged connection (1" RF forged steel - ANSI specifications). Flange centerline 14" (356 mm). Other centerlines available.



Series 1221 is installed with one horizontal and one vertical 1" NPT combination hub. 1" socket weld optional.

"A" is the level at which single (or lower stage) operates on level rise.
 "B" is the operating differential single (or lower stage) - drop in level to restore switch to original position.
 "C" is the level at which the upper stage operates on level rise.
 "D" is the operating differential of upper stage - drop in level to restore switch to position.
 "E" - the increase in level above "A" to operate upper stage.

Repeatability ± 1/4" (6.4 mm)

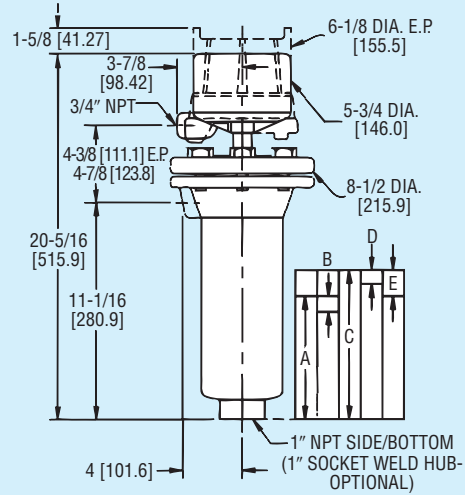

Series 1224 has two vertical flanges (1" RF forged steel - ANSI specifications). Flange centerline 14 5/8" (371 mm) Other centerlines available.

Switch Level Change Single Stage Operation

Switch Level Change Two Stage Operation

	SP GR	A*	B	A*	B	C	D	E	ORDERING CODE
MIN SP GR 0.40 1000 psi (69 bar) @ 100°F (38°C) 850 psi (59 bar) @ 475°F (246°C)	0.40	6 7/16" (164 mm)	5/8" (16 mm)	6 7/16" (164 mm)	5/8" (16 mm)	7 9/16" (192 mm)	5/8" (16 mm)	1 1/8" (29 mm)	C1-40

**"A" is not adjustable.

Level

Low specific gravity and superior long term performance make this Series ideal for applications which require operation at specific gravities as low as 0.40. This Series also provides a heavy duty flanged chamber with removable stainless steel float for easy inspection and maintenance. Chamber is rated for operation of 1000 psig (69 bar) at 100°F (38°C), and 850 psig (59 bar) at 475°F (246°C). 1" NPT process connections are standard. Socket weld hubs or flanged connections are optional. Various circuits are available in SPST, SPDT or DPDT configurations with hermetically sealed snap action or mercury contacts. Enclosures are general purpose, (weatherproof) (explosion-proof) or (explosion-proof - vapor proof).

APPLICATIONS

Oil refineries, chemical plants, power generating stations, pumping stations, heat transfer systems, sanitary/waste water facilities, drip legs, hydraulic systems, boilers.

SPECIFICATIONS

Minimum Specific Gravity: 0.40. Process pressure 1000 psig (69 bar) at 100°F (38°C); 850 psig (59 bar) at 475°F (246°C).

Switch Type: Snap action or mercury. See charts A and B.

Electrical Rating: See charts A and B.

Wiring Connections: G, WT or E enclosure, terminal block. EV enclosure, 18" (460 mm) leads.

Process Connections: 1" NPT or flanges. See model chart. (19 socket weld hubs optional).

Enclosures: G, painted steel and aluminum. WT, painted steel, aluminum, neoprene. E, aluminum. EV, aluminum, neoprene.

Wetted Parts: C1 construction. Chamber, carbon steel. Trim 303SS, 304SS, 316SS and 430SS.

Weight: 1221, 64 lb (29 kg); 1223, 74 lb (33.6 kg); 1224, 81 lb (36.7 kg).

Suggested Specifications:

Liquid level control shall be 1221 (1223) (1224) Series with flanged carbon steel chamber and removable float. Process connections shall be 1" NPT (socket weld hubs) (flanged). Control shall be suitable for operation at 1000 psi (69 bar) at 100°F (38°C), and 850 psig (59 bar) at 475°F (246°C) with a minimum specific gravity of 0.40 (C1-40). Circuit shall be (hermetically sealed) snap action (mercury) switch (SPST) (SPDT) (DPDT) with fixed deadband. Switch mechanism shall be gravity return and shall be activated by a stainless steel float. Enclosure shall be general purpose, (weatherproof) (explosion-proof) (explosion-proof - vapor proof).

MODEL CHART - SERIES 1221

EXAMPLE	1221	WT	7810	10	HF	C1	40		1221-WT-7810-C1-40. Liquid level control. Flanged carbon steel chamber. Weather proof enclosure. SPDT snap switch, fixed deadband, automatic reset. Operating pressure 1000 psig (69 bar) at 100°F (38°C), 850 psig (59 bar) at 475°F (246°C). Side/bottom process connections, 1" NPT hubs. Minimum specific gravity 0.40.		
ENCLOSURE		G WT E EV							General purpose, NEMA-1. Weather proof, NEMA-3R, 4, 4X. Explosion proof, NEMA-7, 9. Class I Groups B, C, D. Class II Groups E, F, G. (CSA approved Groups C, D, E, F, G only). Explosion proof, vapor proof, NEMA-7, 9. Class I Groups B, C, D. Class I Groups E, F, G (CSA approved groups C, D, E, F, G only).	UL UL UL	CSA CSA CSA
CIRCUITS (For Electrical Circuits see charts A & B below.)			48XX 48XX 78XX 78XX 78XXHM 98XX 98XX	XX XX XX					Single stage. Mercury switch. See Chart A. Two stage. Mercury switch. See Chart A. Single stage. Snap switch. See Chart B. Two stage. Snap switch. See Chart B. Hermetically sealed snap switch. See Chart B. Single stage. High capacity DC snap switch. Use heat fins (HF) if process temperature exceeds 350°F (177°C). Do not exceed 450°F (232°C). See Chart B. Two stage. High capacity DC snap switch. Use heat fins (HF) if process temperature exceeds 350°F (177°C). Do not exceed 450°F (232°C). See Chart B.		
FLANGED CHAMBER CONSTRUCTION 1" NPT HUBS	1221					C1 C1	40		Carbon steel body. Minimum specific gravity 0.40. Side/bottom process connections. 1" NPT hub. Pressure rating 1000 psig (69 bar) at 100°F (38°C), 850 psig (59 bar) at 475°F (246°C).	UL UL	CSA CSA
FLANGED CHAMBER CONSTRUCTION WITH FLANGED PROCESS CONNECTIONS	1223					C1	140		1" 150# flanges side/bottom process connection. Pressure rating 275 psi (19 bar) at 100°F (38°C), 150 psi (10 bar) at 475°F (246°C). Minimum specific gravity 0.40.	UL	CSA
	1223					C1	340		1" 300# flanges side/bottom process connection. Pressure rating 720 psi (50 bar) at 100°F (38°C), 625 psi (43 bar) at 475°F (246°C). Minimum specific gravity 0.40.	UL	CSA
	1223					C1	640		1" 600# flanges side/bottom process connection. Pressure rating 1000 psi (69 bar) at 100°F (38°C), 850 psi (59 bar) at 475°F (246°C). Minimum specific gravity 0.40.	UL	CSA
	1224					C1	140		1" 150# flanges side/side process connection. Pressure rating 275 psi (19 bar) at 100°F (38°C), 150 psi (10 bar) at 475°F (246°C). Minimum specific gravity 0.40.	UL	CSA
	1224					C1	340		1" 300# flanges side/side process connection. Pressure rating 720 psi (50 bar) at 100°F (38°C), 625 psi (43 bar) at 475°F (246°C). Minimum specific gravity 0.40.	UL	CSA
	1224					C1	640		1" 600# flanges side/side process connection. Pressure rating 1000 psi (69 bar) at 100°F (38°C), 850 psi (59 bar) at 475°F (246°C). Minimum specific gravity 0.40.	UL	CSA
OPTIONS					HF		H2 12		High temperature fins should be considered if process temperature exceeds 350°F (177°C) for 98XX circuits. 1" socket weld hub instead of 1" NPT. Breather and drain for E type enclosure. Recommended for high humidity or outdoor service.		



CHARTS A & B - ELECTRICAL CIRCUITS AND RATINGS

SWITCH TYPE	SWITCH ACTION	ELECTRICAL RATINGS IN AMPS						ORDERING CODE			UL	CSA
		AC			DC			SINGLE STAGE	TWO STAGE			
		120V	240V	440V	30V	125V	250V		LOWER	UPPER		
CHART A Mercury Contacts	SP-ST Open on level FALL	10	5	3†		10	5	-4820	-4820	-21	UL	CSA
	SP-ST Open on level RISE	10	5	3†		10	5	-4821	-4821	-20	UL	CSA
	SP-DT One Switch	4	2	1†		4	2	-4810	-4810	-10	UL	CSA
	SP-DT Two switches E.I.*	10	5	3†		10	5	-4815	-4815	-15	UL	CSA
	DP-ST Two switches E.I.* Open on level FALL	10	5	3†		10	5	-4814	-4814	-13	UL	CSA
	DP-ST Two switches E.I.* Open on level RISE	10	5	3†		10	5	-4813	-4813	-14	UL	CSA
	DP-DT Two SP-DT switches	4	2	1†		4	2	-4806	-4806	-06	UL	CSA
CHART B Snap Action Contacts	SP-DT One switch	12	5	3†		0.5**	0.25**	-7810	-7810	-10	UL	CSA
	DP-DT Two SP-DT switches	12	5	3†		0.5**	0.25**	-7806	-7806	-06	UL	CSA
	SP-DT One hermetically sealed switch	5	5		5**			-7810HM	-7810HM	-10HM		
	DP-DT Two hermetically sealed SP-DT switches	5	5		5**			-7806HM	-7806HM	-06HM		
	DP-DT Two SP-DT switches	10	3			10‡	3‡	-9806	-9806	-06		
SP-DT One switch	10	3			10‡	3‡	-9810	-9810	-10			

*Electrically Independent †Available on special order. Change 1st digit in Ordering Code from 4 to 5 or 7 to 8 i.e. -4820 becomes -5820, -7810 becomes -8810, etc.
‡10 Amp inductive (Polarized) at 125 VDC
**Resistive