



Series 1251

# Welded Chamber

Min. Specific Gravity 0.40, Pressure to 1250 psig (86 bar), and Temperature to 500°F (260°C), Hermetically Sealed Switches



Series 1253 has one vertical and one horizontal flanged connection (1" RF forged steel - ANSI specifications). Flange centerline 14" (356 mm). Other centerlines available.



Series 1251 is installed with one horizontal and one vertical 1" socket weld or 1" NPT combination hub.

"A" is the level at which single (or lower stage) operates on level rise.  
 "B" is the operating differential single (or lower stage) - drop in level to restore switch to original position.  
 "C" is the level at which the upper stage operates on level rise.  
 "D" is the operating differential of upper stage - drop in level to restore switch to position.  
 "E" - the increase in level above "A" to operate upper stage.

Repeatability ± 1/4" (6.4 mm)

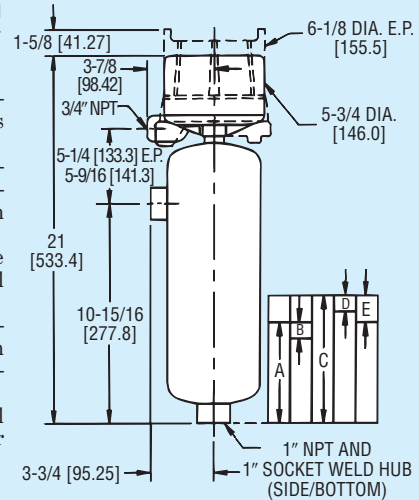

Series 1254 has two vertical flanges (1" RF forged steel - ANSI specifications). Flange centerline 14 5/8" (371 mm). Other centerlines available.

### Switch Level Change Single Stage Operation

### Switch Level Change Two Stage Operation

	SP GR	A*	B	A*	B	C	D	E	ORDERING CODE
MIN SP GR 0.40 1250 psi (86 bar) @ 100°F (38°C)	1.0	5 3/8" (137 mm)	1/2" (13 mm)	5 3/8" (137 mm)	1/2" (13 mm)	6 3/8" (162 mm)	1/2" (13 mm)	1" (25 mm)	C1-40
1250 psi (86 bar) @ 500°F (260°C)	0.4	6 5/16" (160 mm)	5/8" (16 mm)	6 5/16" (160 mm)	5/8" (16 mm)	7 7/16" (189 mm)	5/8" (16 mm)	1 1/8" (29 mm)	

\*"A" is not adjustable.

Level

**Leak proof all welded** heavy duty carbon steel bodies coupled with snap action or mercury switches provide reliable, long term service for compatible liquids. The use of an external magnet reduces the possibility of magnetic particle build-up inside the armature tube and subsequent loss of operation as may occur with the internal magnet repulsion design. A variety of snap action or mercury switches in SPST, SPDT, DPDT or DPST configurations will satisfy most electrical requirements. These switch assemblies are contained in NEMA-1 general purpose, NEMA-4X weatherproof, NEMA-7-9 groups B, C, D, E, F, G, explosion-proof or explosion-proof - vapor proof enclosures.

### APPLICATIONS

Refineries, chemical plants, power generating stations, water treatment plants, mixing systems, scrubbers, accumulators, condensate recovery, industrial tanks and vessels.

### SPECIFICATIONS

**C1-40:** Minimum specific gravity 0.40. Process pressure 1250 psi (86 bar) at 100°F (38°C) to 500°F (260°C).

**Switch Type:** Snap action or mercury. See charts A and B.

**Electrical Rating:** See charts A and B.

**Wiring Connections:** G, WT or E enclosure, terminal block. EV enclosure, 18" (460 mm) leads.

**Process Connection:** Combination 1" NPT/socket weld hubs or flanges. See model chart.

**Enclosures:** G, painted steel and aluminum. WT, painted steel, aluminum and neoprene. E, aluminum. EV, aluminum and neoprene.

**Wetted Parts:** C1 construction. Chamber, carbon steel. Trim, 303SS, 304SS, 316SS and 430SS.

**Weight:** 1251, 40 lb (18 kg); 1253, 50 lb (22.7 kg); 1254, 57 lb (25.8 kg).

### Suggested Specifications

Liquid level control shall be 1251 (1253) (1254) Series with 1" combination NPT/socket weld hub (flanged) process connections. Chamber shall be welded and suitable for operation at 1250 psig (86 bar) and 500°F (260°C) with a minimum specific gravity of 0.40. Circuit shall be hermetically sealed snap action (mercury) switch (SPST) (SPDT) (DPDT). Enclosure shall be general purpose, (explosion-proof) (explosion-proof - vapor proof). Switch mechanism shall be gravity return and shall be activated by a stainless steel float.

**MODEL CHART – SERIES 1251**

<b>EXAMPLE</b>	1251	WT	7810	10	C1	40		1251-WT-7810-C1-40. Liquid level control. Welded carbon steel chamber. Weather proof enclosure. SPDT snap switch, fixed deadband, automatic reset. Operating pressure 1250 psig (86 bar) at 100°F (38°C), 1250 psig (86 bar) at 500°F (260°C). Side/bottom process connections, combination 1" NPT/socket weld hubs. Minimum specific gravity 0.40.	
<b>ENCLOSURE</b>		G WT E EV						General purpose, NEMA-1. Weather proof, NEMA-3R, 4, 4X. Explosion proof, NEMA-7, 9. Class I Groups B, C, D. Class II Groups E, F, G. Explosion proof, vapor proof. NEMA-7, 9. Class I Groups B, C, D. Class II Groups E, F, G.	UL UL UL UL
<b>CIRCUITS</b>  (For Electrical Circuits see charts A & B below.)			48XX 48XX 78XX 78XX 78XXHM 98XX  98XX	XX  XX  XX				Single stage. Mercury switch. See Chart A. Two stage. Mercury switch. See Chart A. Single stage. Snap switch. See Chart B. Two stage. Snap switch. See Chart B. Hermetically sealed snap switch. See Chart B. Single stage. High capacity DC snap switch. Use heat fins (HF) if process temperature exceeds 350°F (177°C). Do not exceed 450°F (232°C). See Chart B. Two stage. High capacity DC snap switch. Use heat fins (HF) if process temperature exceeds 350°F (177°C). Do not exceed 450°F (232°C). See Chart B.	
<b>WELDED CHAMBER CONSTRUCTION COMBINATION 1" NPT/SOCKET WELD HUBS</b>	1251				C1 C1	40		Carbon steel body. Minimum specific gravity 0.40. Side/bottom process connections. Combination 1" NPT/socket weld hub. Pressure rating 1250 psig (86 bar) at 100°F (38°C) to 500°F (260°C).	UL UL
<b>WELDED CHAMBER CONSTRUCTION WITH FLANGED PROCESS CONNECTIONS</b>	1253				C1	140		1" 150# flanges side/bottom process connection. Pressure rating 275 psi (19 bar) at 100°F (38°C), 150 psi (10 bar) at 500°F (260°C). Minimum specific gravity 0.40.	UL
	1253				C1	340		1" 300# flanges side/bottom process connection. Pressure rating 720 psi (50 bar) at 100°F (38°C), 625 psi (43 bar) at 500°F (260°C). Minimum specific gravity 0.40.	UL
	1253				C1	640		1" 600# flanges side/bottom process connection. Pressure rating 1250 psi (86 bar) at 100°F (38°C), 1250 psi (86 bar) at 500°F (260°C). Minimum specific gravity 0.40.	UL
	1254				C1	140		1" 150# flanges side/side process connection. Pressure rating 275 PSI (19 bar) at 100°F (38°C), 150 psi (10 bar) at 500°F (260°C). Minimum specific gravity 0.40.	UL
	1254				C1	340		1" 300# flanges side/side process connection. Pressure rating 720 psi (50 bar) at 100°F (38°C), 625 psi (43 bar) at 500°F (260°C). Minimum specific gravity 0.40.	UL
	1254				C1	640		1" 600# flanges side/side process connection. Pressure rating 1250 psi (86 bar) at 100°F (38°C), 1250 psi (86 bar) at 500°F (260°C). Minimum specific gravity 0.40.	UL
<b>OPTIONS</b>					C216	12		316SS chamber and trim. 430SS armature. Breather and drain for E type enclosure. Recommended for high humidity or outdoor service.	UL

Level

**CHARTS A & B - ELECTRICAL CIRCUITS AND RATINGS**

SWITCH TYPE	SWITCH ACTION	ELECTRICAL RATINGS IN AMPS						ORDERING CODE			
		AC			DC			SINGLE STAGE	TWO STAGE		
		120V	240V	440V	30V	125V	250V		LOWER	UPPER	
<b>CHART A</b> Mercury Contacts	SP-ST Open on level FALL	10	5	3†		10	5	-4820	-4820	-21	UL
	SP-ST Open on level RISE	10	5	3†		10	5	-4821	-4821	-20	UL
	SP-DT One Switch	4	2	1†		4	2	-4810	-4810	-10	UL
	SP-DT Two switches E.I.*	10	5	3†		10	5	-4815	-4815	-15	UL
	DP-ST Two switches E.I.* Open on level FALL	10	5	3†		10	5	-4814	-4814	-13	UL
	DP-ST Two switches E.I.* Open on level RISE	10	5	3†		10	5	-4813	-4813	-14	UL
	DP-DT Two SP-DT switches	4	2	1†		4	2	-4806	-4806	-06	UL
<b>CHART B</b> Snap Action Contacts	SP-DT One switch	12	5	3†		0.5**	0.25**	-7810	-7810	-10	UL
	DP-DT Two SP-DT switches	12	5	3†		0.5**	0.25**	-7806	-7806	-06	UL
	SP-DT One hermetically sealed switch	5	5		5**			-7810HM	-7810HM	-10HM	
	DP-DT Two hermetically sealed SP-DT switches	5	5		5**			-7806HM	-7806HM	-06HM	
	DP-DT Two SP-DT switches	10	3			10‡	3‡	-9806	-9806	-06	
	SP-DT One switch	10	3			10‡	3‡	-9810	-9810	-10	

\*Electrically Independent †Available on special order. Change 1st digit in Ordering Code from 4 to 5 or 7 to 8  
‡10 Amp inductive (Polarized) at 125 VDC i.e. -4820 becomes -5820, -7810 becomes -8810, etc.  
\*\*Resistive