



Series 251

Welded Chamber

External Mount Pressure to 1250 psig (86 bar), Hermetically Sealed Switches, Temperature to 750°F (400°C), Explosion-Proof Housings



Series 253 has one vertical and one horizontal flanged connection (1" RF forged steel - ANSI specifications). Flange centerline 14" (356 mm). Other centerlines available.



Series 251 is installed with one horizontal and one vertical 1" socket weld or 1" NPT combination hub.

"A" is the level at which single (or lower stage) operates on level rise.

"B" is the operating differential single (or lower stage) - drop in level to restore switch to original position.

"C" is the level at which the upper stage operates on level rise.

"D" is the operating differential of upper stage - drop in level to restore switch to position.

"E" - the increase in level above "A" to operate upper stage.

Repeatability ± 1/4" (6.4 mm)

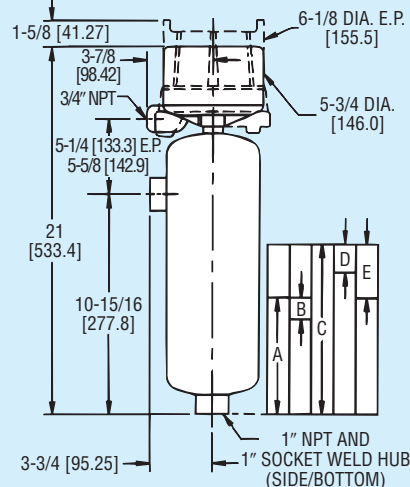

Series 254 features two vertical flanged connections (1" RF forged steel - ANSI specifications). Flange centerline 14 5/8" (371 mm). Other centerlines available.

Switch Level Change Single Stage Operation

Switch Level Change Two Stage Operation

	SP GR	A*	B	A**	B	C	D	E	ORDERING CODE
MIN SP GR 0.75 1250 psi (86 bar) @ 100°F (38°C) to 650°F (345°C) 750 psi (52 bar) @ 750°F (400°C)	1.0	7 1/4" (184 mm)	3/4" (19 mm)	6 1/4" (159 mm)	3/4" (19 mm)	8 1/2" (216 mm)	1 1/4" (32 mm)	2 1/4" (57 mm)	C1-75
	0.75	8" (203 mm)	1" (25.4 mm)	7" (178 mm)	1" (25.4 mm)	9 1/2" (241 mm)	1 3/4" (44 mm)	2 1/2" (64 mm)	

**"A" is adjustable ± 1".

**"A" is not adjustable.

Time proven magnetic head leak proof construction combines with a heavy duty welded chamber to provide excellent reliability for control of compatible liquids. Operating pressures of 1250 psig (86 bar) at 650°F (345°C) and 750 psig (52 bar) at 750°F (400°C) are standard. The use of an external magnet reduces the possibility of magnetic particle build up inside the armature tube and subsequent loss of operation as may occur with the internal magnet repulsion design. The controls feature carbon steel bodies and stainless steel internal trim. Process mounting configurations include either side/bottom combination 1" NPT/socket weld hubs, side/bottom flanges or side/side flanges. A variety of hermetically sealed snap action or mercury switches are available in SPST, SPDT, or DPDT action for single or two stage operation. Mercury or Gold alloy snap action contacts are suitable for low current DC applications. A full range of switch enclosures are offered. Many chamber, enclosure and switch combinations are UL approved.

APPLICATIONS

Refineries, chemical plants, power generating stations, water treatment plants, mixing systems, scrubbers, accumulators, condensate recovery, industrial tanks and vessels.

SPECIFICATIONS

C1-75: Minimum specific gravity 0.75. Process pressure 1250 psig (86 bar) at 100°F (38°C), to 650°F (345°C). 750 psig (52 bar) at 750°F (400°C).*

*Heat fins and/or high temperature switches should be considered for process temperatures above 500°F (260°C).

Switch Types: Snap action or mercury. See charts A and B.

Electrical Rating: See charts A and B.

Wiring Connections: G, WT or E enclosure, terminal block. EV enclosure 18" (460 mm) leads.

Process Connections: Combination 1" NPT/socket weld hubs or flanges. See model chart.

Enclosures: G painted steel and aluminum. WT, painted steel, aluminum and neoprene. E, aluminum. EV, aluminum, neoprene.

Wetted Parts: C1 construction, carbon steel, 303SS, 304SS, 316SS, 430SS. (Optional 316SS with 430SS).

Weight: 251, 40 lb (18 kg); 253, 50 lb (22.7 kg); 254, 57 lb (25.8 kg).

Suggested Specifications

Liquid level control shall be 251 (253) (254) Series with combination 1" NPT/socket weld hubs (flanged) process connections. Chamber shall be welded carbon steel (316SS) suitable for operation at 1250 psig (86 bar) at 100°F (38°C) to 650°F (345°C), 750 psig (52 bar) at 750°F (400°C) at a minimum specific gravity of 0.75. Circuit shall be (hermetically sealed) snap action (mercury) switch (SPST) (SPDT) (DPDT). Enclosure shall be general purpose (weather proof) (explosion-proof) (explosion-proof - vapor proof). Switch mechanism shall be gravity return and shall be activated by a stainless steel float.

Level

MODEL CHART – SERIES 251

EXAMPLE	251	WT	7810	GLD	10	GLD	HF	C1	75	251-WT-7810-C1-75. Liquid level control. Welded carbon steel chamber. Weather proof enclosure. SPDT snap switch, fixed deadband, automatic reset. Operating pressure 1250 psig (86 bar) at 650°F (345°C), 750 psig (52 bar) at 750°F (400°C). Side/bottom process connections, combination 1" NPT/socket weld hubs., minimum specific gravity 0.75.	
ENCLOSURE		G WT E EV								General purpose, NEMA-1. Weather proof, NEMA-3R, 4, 4X. Explosion proof, NEMA-7, 9. Class I Group B, C, D. Class II Group E, F, G. Explosion proof, vapor proof, NEMA-7, 9. Class I Group B, C, D. Class II Group E, F, G.	UL UL UL UL
CIRCUITS (For Electrical Circuits see charts A & B below.)			48XX 48XX 78XX 78XX 78XXHM 98XX 98XX 10XX 10XX		XX XX XX XX					Single stage. Mercury switch. See Chart A. Two stage. Mercury switch. See Chart A. Single stage. Snap switch. See Chart B. Two stage. Snap switch. See Chart B. Hermetically sealed snap switch. See Chart B. Single stage. High capacity DC snap switch. Use heat fins (HF) if process temperature exceeds 350°F (177°C). Do not exceed 450°F (232°C). See Chart B. Two stage. High capacity DC snap switch. Use heat fins (HF) if process temperature exceeds 350°F (177°C). Do not exceed 450°F (232°C). See Chart B. Single stage. High temperature snap switch. Continuous rating 800°F (425°C). See Chart B. 251-C1-75 type rated at 650 psi (45 bar). Two stage. High temperature snap switch. Continuous rating 800°F (425°C). See Chart B. 251-C1-75 type rated at 650 psi (45 bar).	
WELDED CHAMBER CONSTRUCTION COMBINATION 1" NPT/SOCKET WELD HUBS	251							C1 C1	75	Carbon steel body. Minimum specific gravity 0.75. Side/bottom process connections. Combination 1" NPT/socket weld hub. Pressure rating 1250 psig (86 bar) at 100°F (38°C), to 650°F (345°C), 750 psig (52 bar) at 750°F (400°C), V.	UL UL
WELDED CHAMBER CONSTRUCTION WITH FLANGED PROCESS CONNECTIONS	253							C1	175	1" 150# flanges side/bottom process connection. Pressure rating 275 psi (19 bar) at 100°F (38°C), 100 psi (7 bar) at 750°F (400°C). Minimum specific gravity 0.75.	UL
	253							C1	375	1" 300# flanges side/bottom process connection. Pressure rating 720 psi (50 bar) at 100°F (38°C), 425 psi (29 bar) at 750°F (400°C). Minimum specific gravity 0.75.	UL
	253							C1	675	1" 600# flanges side/bottom process connection. Pressure rating 1250 psi (86 bar) at 100°F (38°C), 750 psi (52 bar) at 750°F (400°C). Minimum specific gravity 0.75.	UL
	254							C1	175	1" 150# flanges side/side process connection. Pressure rating 275 psi (19 bar) at 100°F (38°C), 100 psi (7 bar) at 750°F (400°C). Minimum specific gravity 0.75.	UL
	254							C1	375	1" 300# flanges side/side process connection. Pressure rating 720 psi (50 bar) at 100°F (38°C), 425 psi (29 bar) at 750°F (400°C). Minimum specific gravity 0.75.	UL
	254							C1	675	1" 600# flanges side/side process connection. Pressure rating 1250 psi (86 bar) at 100°F (38°C), 750 psi (52 bar) at 750°F (400°C). Minimum specific gravity 0.75.	UL
OPTIONS				GLD		GLD		HF C216	12	Gold alloy contact for low current service rated at 1 amp resistive, 0.5 amp inductive 28 VDC. Circuit 7810 or 7806 only. High temperature fins should be considered if ambient temperature is extremely high or if process temperature exceeds 500°F (260°C) for extended periods. 316SS chamber and trim. 430SS armature. Breather and drain for E type enclosure. Recommended for high humidity or outdoor service.	

Level

CHARTS A & B - ELECTRICAL CIRCUITS AND RATINGS

SWITCH TYPE	SWITCH ACTION	ELECTRICAL RATINGS IN AMPS						ORDERING CODE			
		AC			DC			SINGLE STAGE	TWO STAGE		
		120V	240V	440V	30V	125V	250V		LOWER	UPPER	
CHART A Mercury Contacts	SP-ST Open on level FALL	10	5	3‡		10	5	-4821	-4821	-21	UL
	SP-ST Open on level RISE	10	5	3‡		10	5	-4820	-4820	-20	UL
	SP-DT One Switch	4	2	1‡		4	2	-4810	-4810	-10	UL
	SP-DT Two switches E.I.*	10	5	3‡		10	5	-4815	-4815	-15	UL
	DP-ST Two switches E.I.* Open on level FALL	10	5	3‡		10	5	-4813	-4813	-13	UL
	DP-ST Two switches E.I.* Open on level RISE	10	5	3‡		10	5	-4814	-4814	-14	UL
	DP-DT Two SP-DT switches	4	2	1‡		4	2	-4806	-4806	-06	UL
CHART B Snap Action Contacts	SP-DT One switch	12	5	3‡		0.5**	0.25**	-7810	-7810	-10	UL
	DP-DT Two SP-DT switches	12	5	3‡		0.5**	0.25**	-7806	-7806	-06	UL
	SP-DT One hermetically sealed switch	5	5		5**			-7810HM	-7810HM	-10HM	
	DP-DT Two hermetically sealed SP-DT switches	5	5		5**			-7806HM	-7806HM	-06HM	
	DP-DT Two SP-DT switches	10	3			10‡	3‡	-9806	-9806	-06	
	SP-DT One switch	10	3			10‡	3‡	-9810	-9810	-10	
	DP-DT Two SP-DT switches	2	2			0.4**	0.25**	-1006	-1006	-06	
	SP-DT One switch	2	2			0.4**	0.25**	-1010	-1010	-10	

*Electrically Independent †Available on special order. Change 1st digit in Ordering Code from 4 to 5 or 7 to 8
‡10 Amp inductive (Polarized) at 125 VDC i.e. -4820 becomes -5820, -7810 becomes -8810, etc.
**Resistive