

PROXIMITY® Series 295

Compact Rotary Smart Positioner

Low Cost, Rotary Operation, HART® Communication

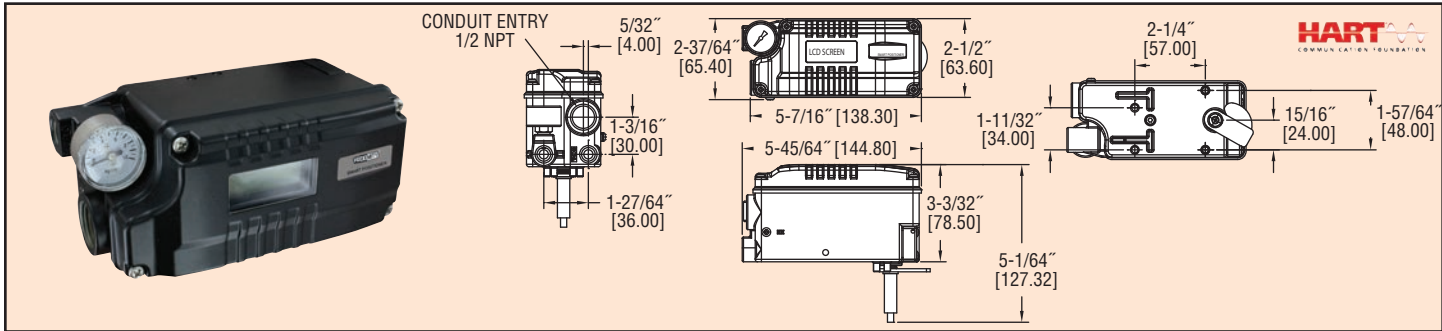

Proximity Series 295 Smart Positioners are a compact, high performance unit with a low price. Series 295 models accurately control the valve stroke of rotary motion valves, such as W.E. Anderson ball or butterfly valves, according to an input signal of 4 to 20 mA from the controller. Its rugged, durable design makes it ideal for harsh environments. The NEMA 4X (IP66) enclosure rating protects the highly efficient microprocessing unit inside the Smart Positioner. An analog feedback signal is outputted to stabilize any valve system and easy to use functions such as auto calibration ensure the accuracy of the unit. Low air consumption reduces operating cost, but does not sacrifice the performance of the Smart Positioner. The handheld size of this unit makes it easy to use with any size actuator, and can be used in applications where a larger positioner may not fit. Series 295 Smart Positioners feature a LCD screen attached to the outer surface of the unit, allowing for an easy inspection of the positioner condition while in the field. Available with HART® communication.

Model	Action	Communication
295ER-S1	Single	None
295ER-S2	Single	HART®

SPECIFICATIONS

Input Signal: 4 to 20 mA DC.

Input Impedance: 460 Ω max @ 20 mA DC.

Enclosure Material: Aluminum.

Air Supply: 35 to 116 psi (2.4 to 8 bar).

Air Connection: 1/4" NPT.

Gate Connection: 1/8" NPT.

Conduit Connection: 1/2" NPT.

Linearity: ±0.5% FS.

Hysteresis: ±0.5% FS.

Sensitivity: ±0.2% FS.

Repeatability: ±0.3% FS.

Air Consumption: .0004 scfm (.01 LPM) at 20 psig (1.4 bar) supply.

Flow Capacity: .32 scfm (9 LPM) at 20 psig (1.4 bar) supply.

Stroke: 0 to 90°.

Enclosure Rating: NEMA 4X (IP66).

Temperature Limits: -22 to 185°F (-30 to 85°C).

Weight: 1.8 lb (.82 kg).

HART® is a registered trademark of Hart Communication Foundation.