



Series 165

PRECISOR® II Pneumatic and Electro-Pneumatic Positioner

Linear Operation, Field Selectable Cam Design, 316 SS Models



VALVES

Positioners

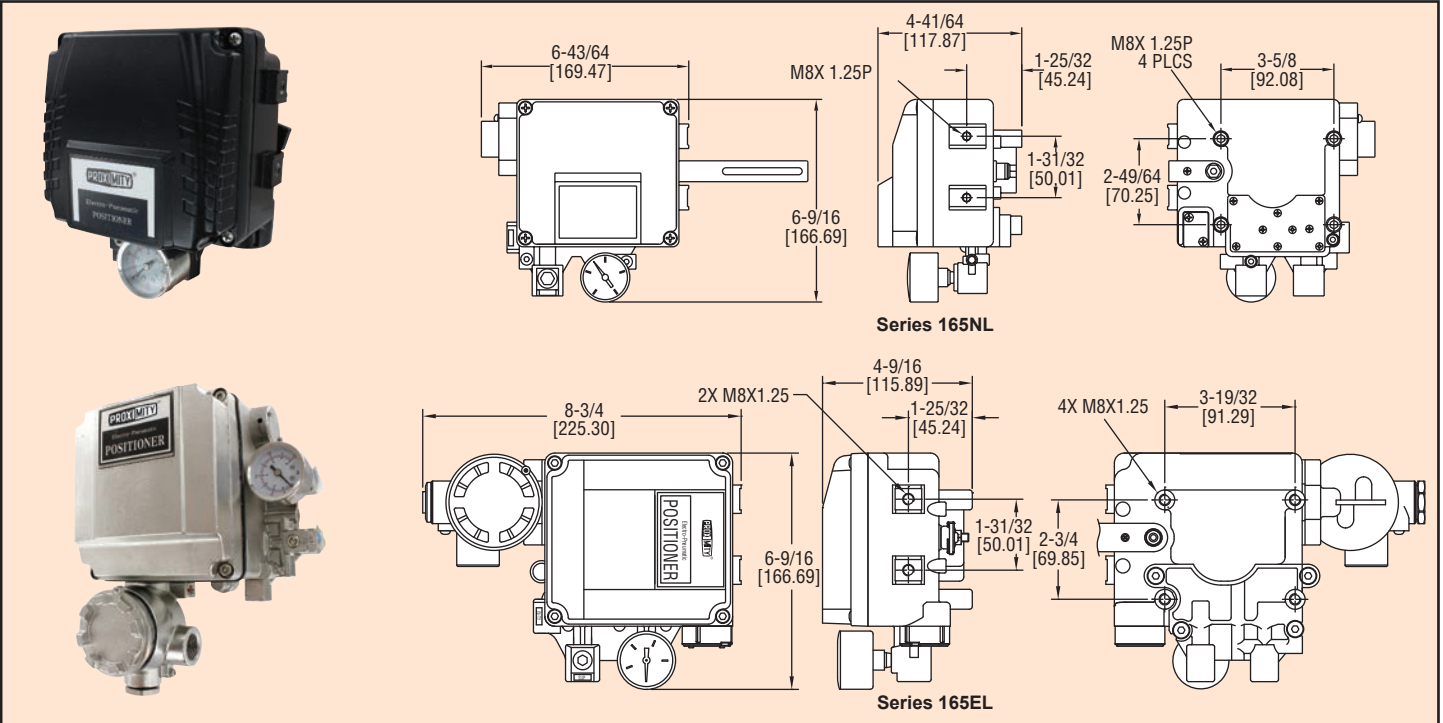

The Series 165 PRECISOR® II Pneumatic and Electro-Pneumatic Positioners deliver stable process control at an exceptionally low price. Its rugged, durable design makes it ideal for harsh environments while maintaining precise, accurate positioning of the control element. Units can be easily changed from direct to reverse action, or vice versa. Low air consumption keeps operating costs at a minimum, while still responding quickly and accurately. Excellent for use in chemical processing, food and beverage, pulp and paper, and pharmaceutical industries, as well as many others.

FEATURE

- Field selectable cam for direct or reverse acting.

Model	Input	Enclosure
165NL	3 to 15 psig	Aluminum
165EL	4 to 20 mA	Aluminum
165EL-SS	4 to 20 mA	Stainless Steel

How To Order:

1. Select Model No. to specify input control signal.
2. For proper mounting hardware, order according to which actuator the positioner will be mounted to:

Mounting Kits

Model	For Actuator Models
A-233	220 and 221 Air-to-Lower
A-234	222 and 223 Air-to-Lower
A-235	230 and 231 Air-to-Raise
A-236	233 Air-to-Raise

Valve Mount: For factory mounting and calibration to Hi-Flow™ control valves, add suffix to valve model number of positioner.
Example: 2004VA32-231-165EL

SPECIFICATIONS

- Input Signal:** Pneumatic: 3 to 15 psig (0.2 to 1 bar); Electro-pneumatic: 4 to 20 mA DC.
- Input Impedance:** (165EL only): 250 ±15 Ω.
- Enclosure Material:** Aluminum diecasting or 316 SS.
- Air Supply:** 20 to 100 psig (1.4 to 6.9 bar).
- Air Supply Connection:** 1/4" NPT.
- Gage Connection:** 1/8" NPT.
- Electrical Connection:** Screw terminal.
- Conduit Connection:** 1/2" NPT (165EL only).
- Linearity:** ±0.2% FS.
- Hysteresis:** 1% FS.
- Sensitivity:** ±0.2% FS.
- Repeatability:** ±0.5% FS.
- Air Consumption:** 0.10 scfm (3 LPM) at 20 psig (1.4 bar) supply.
- Flow Capacity:** 28 scfm (80 LPM) at 20 psig (1.4 bar) supply.
- Stroke:** 0.5 to 6" (10 to 150 mm).
- Enclosure Rating:** IP66 (NEMA 4X).
- Temperature Limits:** Aluminum: -4 to 158°F (-20 to 70°C); SS: -40 to 158°F (-40 to 70°C).
- Weight:** 165NL: 3.1 lb (1.7 kg); 165EL: 6.1 lb (2.7 kg).
- Agency Approvals:** CE (165EL only).

APPLICATIONS

Series 165 PRECISOR® II Pneumatic and Electro-Pneumatic Positioners provide excellent modulating control when used between the Dwyer Temperature Controllers, Current to Pressure Transducer, and the Hi-Flow™ Valve in such industries as the food and beverage processing, chemical, pharmaceutical, and wood pulp and paper.